



COMMERCIAL

## Refrigeration Equipment 2 Glass Door Ice Cube Merchandiser Freezer 49 cu. ft. -9 F (R290)

ITEM # \_\_\_\_\_

MODEL # \_\_\_\_\_

NAME # \_\_\_\_\_

SIS # \_\_\_\_\_

AIA # \_\_\_\_\_



738322 (KCHGICM49FB)

2-Glass Door Ice Cube  
Merchandiser Freezer 49 CU.  
FT -9°F-R290

### Short Form Specification

Item No. \_\_\_\_\_

2-glass door freezer with exterior back and bottom panel in galvanized steel, exterior side and top in painted steel; interior back, side, top and interior bottom panels in 304 stainless steel. Electronic control. R290 gas in refrigeration circuit. ETL Safety and Sanitation certified. 3/5 Years warranty.

### Main Features

- External digital temperature display.
- CFC and HCFC free, highly ecological refrigerant type: R290 (ecological gas in foam: cyclopentane). Hydrocarbon refrigerant gas R290 for the lowest environmental impact (GWP=3), to reduce green house and ozone depletion effects.
- Removable gasket for easy cleaning operations.
- Fin & Tube Condenser improves performance in high temperature environments.
- Automatic Defrost Cooling System provides worry-free performance.
- Electronic Temperature Control, quick and simple to set, with control display for easy monitoring.
- High efficiency components to minimize the energy consumption still guaranteeing the highest performances.
- Cabinet completely insulated with high density polyurethane for low environmental impact.
- Back bottom mounted cooling unit guarantee an easy access and cleaning.

### Construction

- Lockable door.
- Heavy duty casters.
- Magnetic gasket removable without tools for easy cleaning.
- Pre-wired heavy duty power cord.
- Heavy duty door hinges.

APPROVAL: \_\_\_\_\_

Part of



Electrolux  
Professional  
Group

**Kelvinator Commercial**  
www.kelvinatorcommercial.com

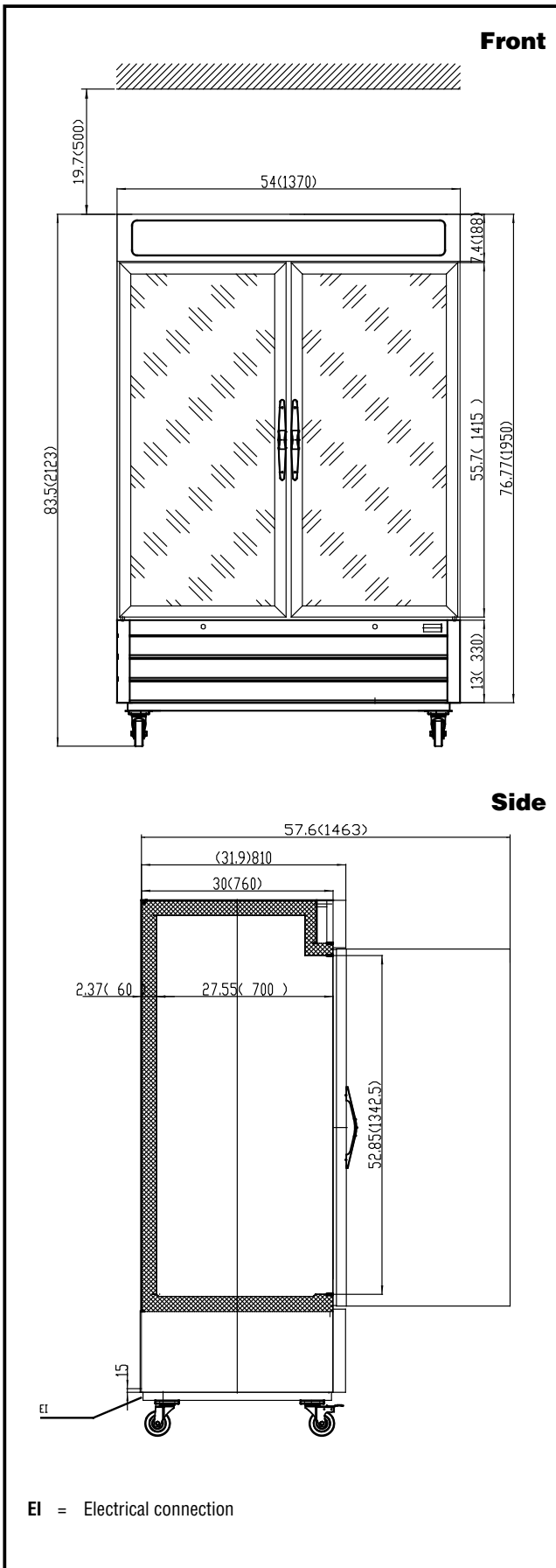

### Electric

Supply voltage:	738322 (KCHGICM49FB)	120 V/1 ph/60 Hz
Electrical power, max:		1.1 kW
Defrost Power		
Plug type:		NEMA 5-15
Maximum Over-Current Protection (MOP):		0A

### Capacity:

Gross capacity:	47.9 cu.feet
-----------------	--------------

### Key Information:

Capacity:	47.884 cu.ft.
External dimensions, Width:	55 1/2" (1410 mm)
External dimensions, Depth:	34 13/16" (885 mm)
External dimensions, Height:	85 13/16" (2180 mm)
Internal Dimensions (depth):	27 9/16"
Internal Dimensions (height):	59 7/16"
Internal Dimensions (width):	49 3/8"
Shipping height:	88 3/16" (2240 mm)
Shipping weight:	586 lbs (266 kg)
Shipping volume:	102.72 ft <sup>3</sup> (2.91 m <sup>3</sup> )

### Refrigeration Data

Operating temperature min.:	18 °F
Operating temperature max.:	15.1 °F
Refrigerant type:	

### Sustainability

Current consumption:	
Refrigerant type:	R290