

Blueair by
BLUENIX

MODEL BLPT28-HC SANDWICH PREP TABLES



Stainless steel cabinet construction

Stainless steel interior and exterior (galvanized steel back & bottom).



Temperature range between 33°F ~ 39°F

Air guard on rear wall ensures proper air circulation and cooling.



Hydrocarbon refrigerants (R-290)

Increases energy HFC refrigerants. It is safer for the environment and does not cause ozone depletion.



Exterior Dimensions (inches/mm)

L	D	H
27 11/16"	33"	42 19/32"
703 mm	839 mm	1082 mm

Weight (lbs/kg)

Net Weight	Ship Weight
157 lbs 71 kg	203 lbs 92 kg

Cabinet construction

- Cyclopentane Insulation – Contains no hydro-fluorocarbons (HFCs) and is environmentally friendly.
- Epoxy coated wire shelves with adjustable shelving height.
- Drop-in section : Fans force cold air into this enclosed area keeping stored food items consistently cold
- Insulated pan cover with a stainless steel divider which prevents food spillage into the storage area beneath
- Standard 1/6 / 4" food pans are provided. Unit accommodates 6" deep pans
- Side rail cutting board bracket with 9 1/2" deep, 1/2" thick cutting board included
- Four 4" Diameter swivel casters with front brakes standard.

Refrigeration

- Self-contained system, rear mounted compressor.
- Electrodeposition coated evaporator increases performance by maintaining the heat transfer rates over the life of the evaporator and reducing potential corrosion.
- Innovative hot gas frame heating system reduces condensation and increases energy.



Conforms to NSF/ANSI 7(ETL)



Front view

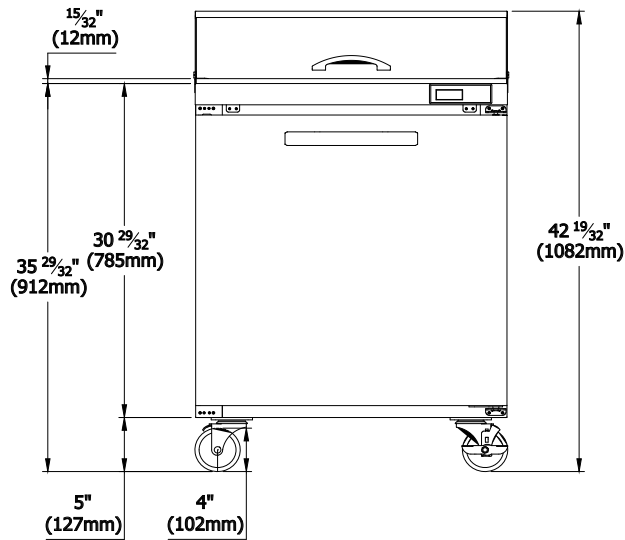

Side view

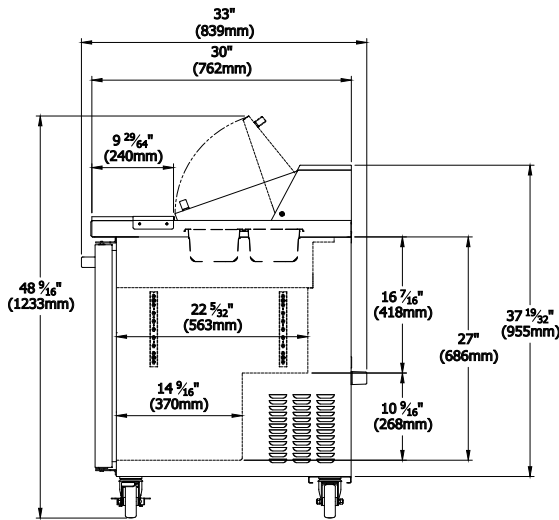

Top view

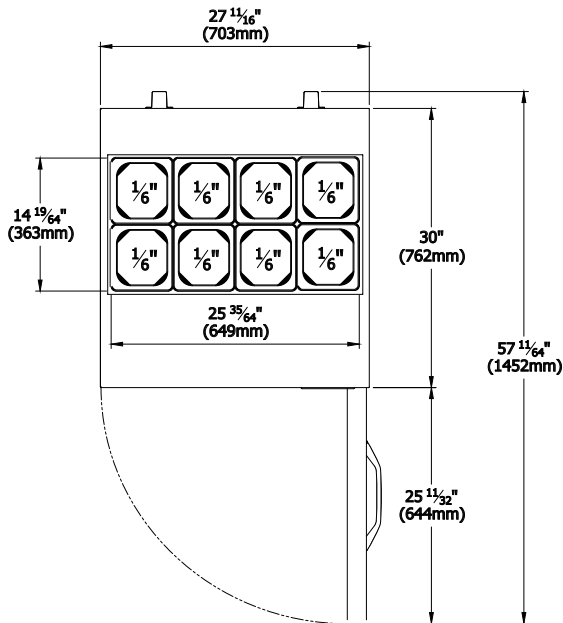

Doors

- Self-closing doors
- Durable door gasket with easy replacement.
- Lifetime guaranteed heavy duty all metal door handles. (Ni-Cr Plated)
- Door designed to open easily.

Design & Features

- Self-diagnostic digital temperature control & monitor system.
- Digital display allows for easy monitoring.
- Digital controls include automatic evaporator fan motor delay
- Rounded corner design gives a stylish appearance and reduces chances of injury.
- Visual and audible door open alarm, alarm sounds when doors are not completely closed to protect against food spoilage

Optional Features & Accessories

- 2.5" diameter casters available.
- Additional shelves are available.
- Drawer models available
- 6" pans available

Doors	1
Capacity Cu.Ft.	7
Shelves	1
Refrigerant	R-290
Temperature Range	33°F ~ 39°F
Easy Maintenance	Sliding Condensing Unit
Connection	9.8 ft long (3m) flexible three wire cord with molded plug
HP	1/4
Voltage	115V/60Hz
Amps	4.0
NEMA Config.	NEMA 5-15

Blue Air has right to change specifications without further notice.



- This product may expose you to chemicals including Diisononyl Phthalate(DINP), which is known to the State of California to cause cancer. For more information go to www.P65Warnings.ca.gov.
- Ce produit peut vous exposer à des agents chimiques incluant le Diisononyl Phthalate(DINP), reconnu par l'Etat de Californie comme causant le cancer. Pour de plus amples renseignements, consulter le site www.P65Warnings.ca.gov.



blueairfse.com



orders@blueairfse.com



1-886-677-8500



223 W. Rosecrans Ave., CA 90248
T: 310-808-0102

9 W. Shelton Terrace #A, Hillside, NJ 07205
T: 908-688-0970