

# Blueair by BLUENIX

MODEL BSF72-HC

## BOTTOM MOUNT REACH-IN FREEZER

Sleek and durable cooling solution for  
your food and beverages.



Conforms to NSF/ANSI 7(ETL)



### Stainless steel cabinet construction

Stainless steel interior and exterior  
(galvanized steel back & bottom).



### Temperature range between -10°F ~ 5°F

Air guard on rear wall ensures proper air  
circulation and cooling.



### Hydrocarbon refrigerants (R-290)

Increases energy HFC refrigerants. It is  
safer for the environment and does not  
cause ozone depletion.



### Visual and audible door open alarm

Alarm sounds when doors are not completely  
closed to protect against food spoilage



## Cabinet construction

- Cyclopentane Insulation – Contains no hydro-fluorocarbons (HFCs) and is environmentally friendly.
- Epoxy coated wire shelves with adjustable shelving height.
- 4 shelves per compartment.
- Six (6) casters which two (2) have front brakes

## Refrigeration

- Self-contained system, bottom mounted compressor. Electrodeposition coated evaporator increases performance by maintaining the heat transfer rates over the life of the evaporator and reducing potential corrosion.
- Bottom mounted condensation pan.
- Designed to prevent water overflow and increase ventilation.
- Innovative hot gas frame heating system reduces condensation and increases energy.

Front view

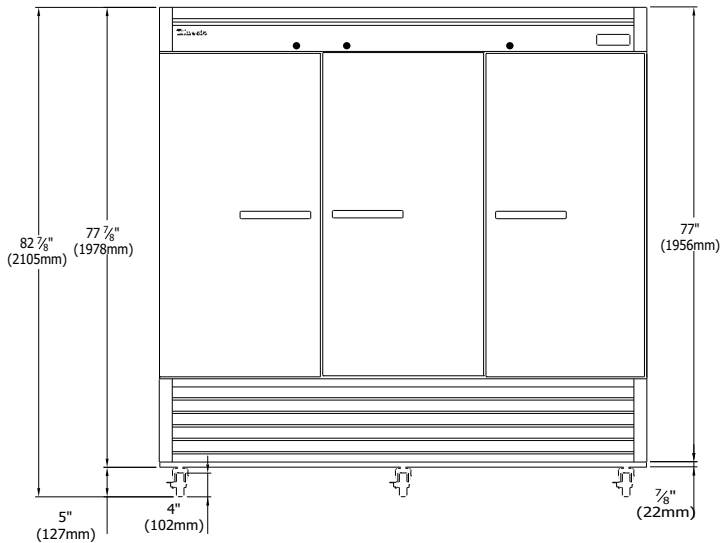

Side view

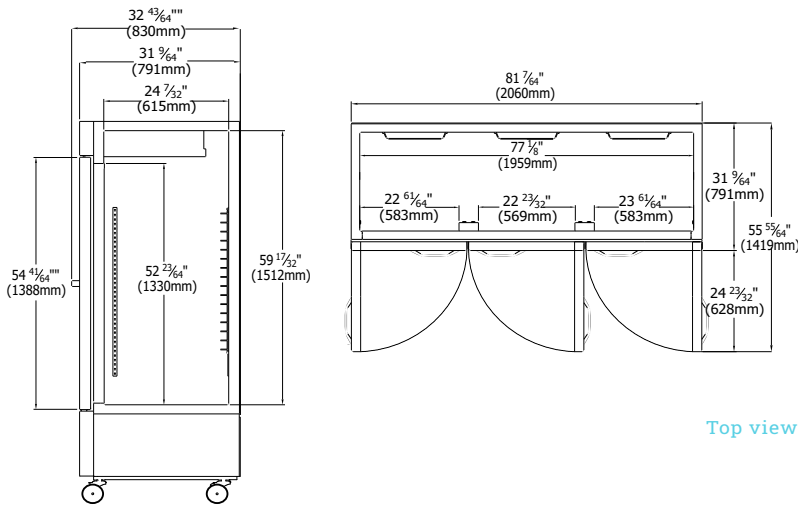

Top view

## Doors

- Self-closing doors (doors close at 90° or less)
- Automatic hold open door feature at 110°.
- Durable door gasket with easy replacement.
- Lifetime guaranteed heavy duty all metal door handles. (Ni-Cr Plated)
- Door designed to open easily.
- Doors built with pressure and with pressure relievers to eliminate vacuum pressure.
- Standard door locks.

## Design & Features

- Self-diagnostic digital temperature control & monitor system.
- Digital display allows for easy monitoring.
- Digital controls include manual defrost for easy maintenance.
- Rounded corner design gives a stylish appearance and reduces chances of injury.

## Optional Features & Accessories

- 2.5" diameter casters available
- 6" adjustable legs available
- Additional shelves are available.

## MODEL BSF72-HC

### BOTTOM MOUNT REACH-IN FREEZER

#### Exterior Dimensions (inches/mm)

L	D	H
81" 2057mm	31 9/64" 791mm	82 7/8" 2105mm

#### Weight (lbs/kg)

Net Weight 626 lbs 284 kg	Ship Weight 653 lbs 296 kg
---------------------------------	----------------------------------

Doors	3
Capacity Cu.Ft.	72
Shelves	12
Refrigerant	R-290
Temperature Range	-10°F ~ 5°F
Easy Maintenance	Sliding Condensing Unit
Connection	9.8 ft long (3m) flexible three wire cord with modeled plug
Lighting	LED Interior lighting
HP	1
Voltage	115V/60Hz
Amps	9.9
NEMA Config.	NEMA 5-15

*Blueair by*  
**BLUENIX**

Blue Air has right to change specifications without further notice.



blueairfse.com



orders@blueairfse.com



1-886-677-8500



223 W. Rosecrans Ave., CA 90248  
T: 310-808-0102

9 W. Shelton Terrace #A, Hillside, NJ 07205  
T: 908-688-0970