

Blueair by
BLUENIX

MODEL BKGM72-HC

GLASS DOOR MERCHANDISER

Sleek and durable cooling solution for your food and beverages.



Stainless steel cabinet construction

Stainless steel interior and exterior (galvanized steel back & bottom).



Temperature range between 33°F ~ 39°F

Air guard on rear wall ensures proper air circulation and cooling.



Hydrocarbon refrigerants (R-290)

Increases energy HFC refrigerants. It is safer for the environment and does not cause ozone depletion.



Visual and audible door open alarm

Alarm sounds when doors are not completely closed to protect against food spoilage

Exterior Dimensions (inches/mm)

L	D	H
81 7/8" 2079 mm	31 3/8" 805 mm	81 3/4" 2065 mm

Weight (lbs/kg)

Net Weight 720 lbs 326 kg	Ship Weight 777 lbs 352 kg
---------------------------------	----------------------------------

Cabinet construction

- Black or white painted steel exterior and white painted steel interior
- High density foamed in place polyurethane insulation – Environmentally safe
- Sturdy, epoxy coated wire shelves with adjustable shelving height
- 4 shelves per compartment.
- Four 4" Diameter swivel casters with front brakes standard.

Refrigeration

- Front sliding refrigeration unit allows the unit to be serviced without being moved.
- Self-contained system, bottom mounted compressor provides quick and easy maintenance.
- Epoxy coated evaporator reduces potential corrosion
- Fabric condensation



Conforms to NSF/ANSI 7(ETL)



Front view

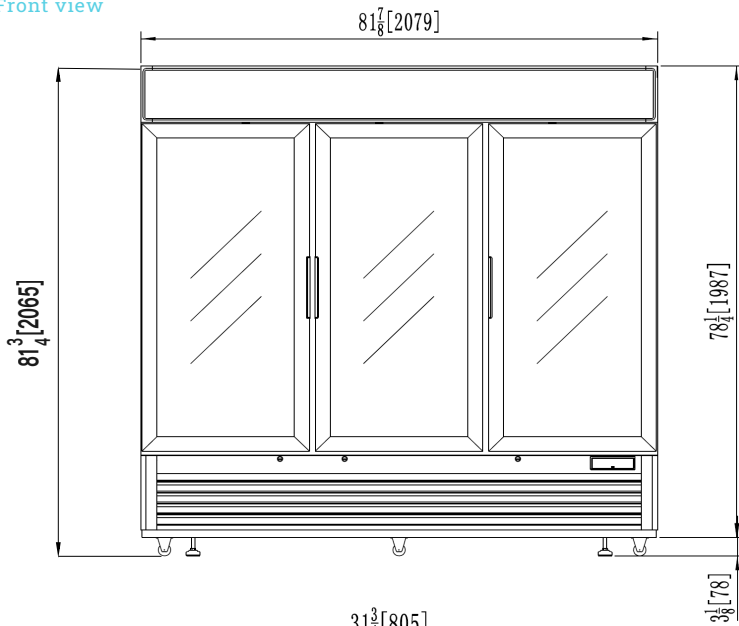

Side view

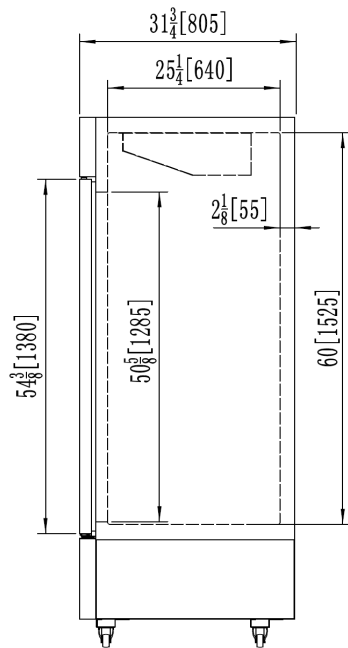

Top view

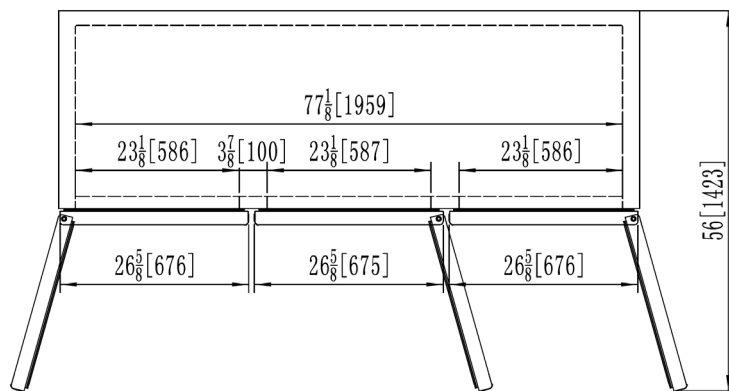

- This product may expose you to chemicals including Diisononyl Phthalate (DINP), which is known to the State of California to cause cancer. For more information go to www.P65Warnings.ca.gov.
 - Ce produit peut vous exposer à des agents chimiques incluant le Diisononyl Phthalate (DINP), reconnu par l'Etat de Californie comme causant le cancer. Pour de plus amples renseignements, consulter le site www.P65Warnings.ca.gov.

Doors

- Self-closing doors (doors close at 90° or less)
- Automatic hold open door feature at 110°.
- Durable door gasket with easy replacement.
- Heavy duty recess door handles
- Door designed to open easily.
- Doors built with pressure and with pressure relievers to eliminate vacuum pressure.
- Standard door locks.
- Double pane glass

Design & Features

- Digital temperature control & monitor system
- Keep food products safe by maintaining constant temperatures
- Digital display allows for easy monitoring.
- Programs interpret the condition of refrigeration
- Controls include automatic evaporator fan motor delays

Optional Features & Accessories

- 2.5" diameter casters available
- 6" adjustable legs available
- Additional shelves are available.

Doors	3
Capacity Cu.Ft.	72
Shelves	12
Refrigerant	R-290
Temperature Range	33°F ~ 39°F
Easy Maintenance	Sliding Condensing Unit
Connection	9.8 ft long (3m) flexible three wire cord with modeled plug
Lighting	LED Interior lighting
HP	1/4+ HP
Voltage	115V/60Hz
Amps	4.2
NEMA Config.	NEMA 5-15

Blueair by
BLUENIX

Blue Air has right to change specifications without further notice.



blueairfse.com



orders@blueairfse.com



1-886-677-8500



223 W. Rosecrans Ave., CA 90248
T: 310-808-0102

9 W. Shelton Terrace #A, Hillside, NJ 07205
T: 908-688-0970