

Blueair by BLUENIX

MODEL BSR72T-HC

TOP MOUNT REACH-IN REFRIGERATOR

Sleek and durable cooling solution for
your food and beverages.



Conforms to NSF/ANSI 7(ETL)



Stainless steel cabinet construction

Stainless steel interior and exterior
(galvanized steel back & bottom).



Temperature range between 33°F ~ 39 °F

Air guard on rear wall ensures proper air
circulation and cooling.



Hydrocarbon refrigerants (R-290)

increases energy efficiency by up to 25%
compared to using HFC refrigerants. It is
safer for the environment and does not
cause ozone depletion.



Visual and audible door open alarm

Alarm sounds when doors are not completely
closed to protect against food spoilage

5 YEAR
WARRANTY

PARTS & LABOR

7 YEAR
WARRANTY

COMPRESSORS

Cabinet construction

- Cyclopentane Insulation – Contains no hydro-fluorocarbons (HFCs) and is environmentally friendly.
- Epoxy coated wire shelves with adjustable shelving height.
- 4 shelves per compartment.
- Six (6) casters which two (2) have front brakes

Refrigeration

- Self-contained system, top mounted compressor
Electrodeposition coated evaporator increases performance by
maintaining the heat transfer rates over the life of the evaporator and
reducing potential corrosion.
- Rear mounted condensation pan.
- Designed to prevent water overflow and increase ventilation.
- Innovative hot gas frame heating system reduces
condensation and increases energy efficiency.

Front view

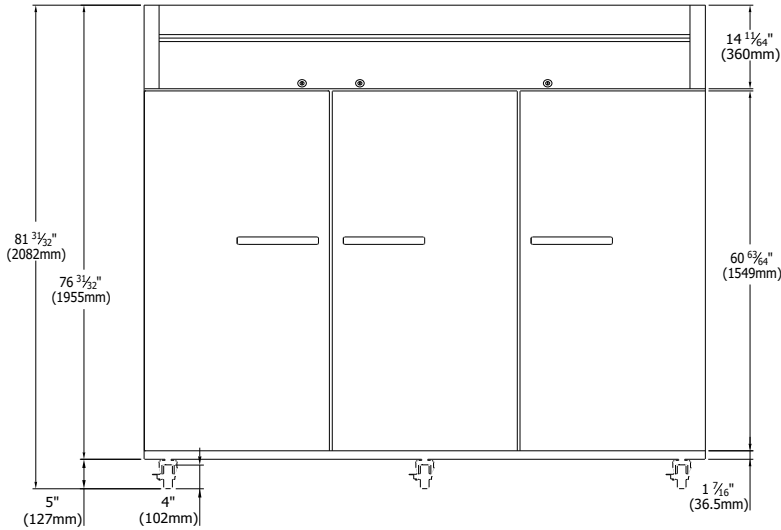

Side view

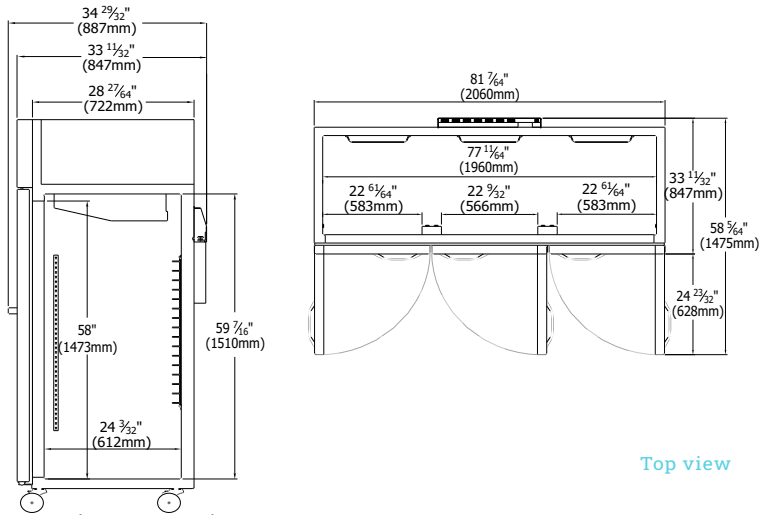

Top view

Doors

- Self-closing doors (doors close at 90° or less)
- Automatic hold open door feature at 110°.
- Durable door gasket with easy replacement.
- Lifetime guaranteed heavy duty all metal door handles. (Ni-Cr Plated)
- Door designed to open easily.
- Doors built with pressure relievers to eliminate vacuum pressure and allow easy door opening.
- Standard door locks.

Design & Features

- Self-diagnostic digital temperature control & monitor system.
- Digital display allows for easy monitoring.
- Digital controls include manual defrost for easy maintenance.
- Rounded corner design gives a stylish appearance and reduces chances of injury.

Optional Features & Accessories

- 2.5" diameter casters available.
- 6" adjustable legs available.
- Additional shelves are available.

MODEL BSR72T-HC

TOP MOUNT REACH-IN REFRIGERATOR

Exterior Dimensions (inches/mm)

L	D	H
81 7/64" 2060mm	33 11/32" 847mm	82 31/32" 2082mm

Weight (lbs/kg)

Net Weight 531 lbs 241 kg	Ship Weight 595 lbs 270 kg
---------------------------------	----------------------------------

Doors	3
Capacity Cu.Ft.	72
Shelves	12
Refrigerant	R-290
Temperature Range	33°F ~ 39°F
Easy Maintenance	Sliding Condensing Unit
Connection	9.8 ft long (3m) flexible three wire cord with modeled plug
Lighting	LED Interior lighting
HP	1/2
Voltage	115V/60Hz
Amps	6.3
NEMA Config.	NEMA 5-15

Blueair by
BLUENIX

Blue Air has right to change specifications without further notice.



blueairfse.com



orders@blueairfse.com



1-886-677-8500



223 W. Rosecrans Ave., CA 90248
T: 310-808-0102

W. Shelton Terrace #A, Hillside, NJ 07205
T: 908-688-0970