



## **BOTTLE COOLER**

---

### Service, Installation and Care Manual

Please read this manual completely before attempting to install or operate this equipment.  
Notify carrier of damage! Inspect all components immediately.



IMPORTANT INFORMATION  
READ BEFORE USE  
PLEASE SAVE THESE INSTRUCTIONS!

## CONTENTS

SPECIFICATIONS.....2

CONGRATULATIONS ON YOUR NEW COOLER.....2

INSTALLATION.....2

ELECTRICAL CONNECTION.....3

OPERATION INSTRUCTIONS.....3

STORAGE OF FOOD STUFFS.....3

DEFROSTING THE CABINET.....3

MAINTENANCE.....3

SAFETY PRECAUTIONS.....6

ELECTRICAL WARNING.....6

TROUBLE SHOOTING.....7

DISPOSAL.....8

SPECIAL PIONTS TO NOTE.....8

WIRING DIAGRAM.....9

## SPECIFICATION

MODEL#	V/Hz/Ph	AMPS	STORAGE CAPACITY Cu-ft	HP	BTU	CHARGE OZ	SHIP WEIGHT LBS	NEMA PLUG
MXCR50B	115/60/1	7	15	1/2	3200	10.6	310	5-15P
MXCR65B	115/60/1	7	20	1/2	5400	11.3	353	5-15P
MXCR96B	115/60/1	7	26	1/2	7600	12.0	439	5-15P

**NOTICE:**

LOSS OR SPOILAGE OF PRODUCTS IN YOUR REFRIGERATOR/FREEZER IS NOT COVERED BY WARRANTY. IN ADDITION TO FOLLOWING RECOMMENDED INSTALLATION PROCEDURES. PLEASE RUN THE REFRIGERATOR/FREEZER 24 HOURS PRIOR TO USAGE. THANK YOU.

## CONGRATULATIONS ON YOUR NEW COOLER

Note these instructions apply to all coolers. Installations of equipment may not exactly correspond to your model.

## INSTALLATION

Make sure that the cooler is not damaged on arrival. Your supplier must be notified of any transport damage, within 24 hours of delivery.

The cooler should be placed in a warm, dry room, with suitable ventilation.

Place the cooler in such a way, as to allow the free circulation of air around it. That is, with at least 100mm

space all around it.

Never place the cooler in strong sunlight. The cooler be placed on a level surface. Make sure that it does not rock.

If the cooler has been stored or transported cold, it must not be started before the compressor is judged to have reached a temperature at least 41°F. It is recommended to clean up the cooler before starting it.

## ELECTRICAL CONNECTION

The cooler must be connected to a socket with the correct voltage/frequency, as show on the nameplate. The standard for u.s is 115V/50HZ. Voltage variations of  $\pm 10\%$  are acceptable. Greater variations can damage the cooler, and in such cases the factory warranty is not valid. In the case of extreme voltage variation, above or below the standard, your local supplier will be able to advise you, what to do.

**The cooler requires extra protection** according to the Danish Heavy Current Regulations.

This also applies, if a new cooler is replaced, which did not have such protection. The purpose of extra protection, is to protect the user from dangerous electric shocks, in the case of defect.

## OPERATION INSTRUCTIONS

The temperature in the cooler is automatically regulated by a pre adjusted thermostat.

The position of the cooler, the ambient temperature, the number of times the lid is opened and for how long the lid is opened, all these factors affect the temperature in the cooler, which should therefore not be placed in sunlight or closed to a heat-radiating surface.

If your cooler is fitted with a lock, the key should be kept out of the reach of children. If your new cooler is to replace an older one, which is not in use any more, you should remove the lock mechanism, on the old one, before disposing it.

## STORAGE OFF FOOD STUFFS

The cooler is only designed as a conserver, and is the not suited to cold freeze foodstuffs. In other words, only refrozen food must be placed in the cooler. Next to that the cooler must not be filled beyond the height limit of the contents line, or in cases where there is no such line, to within 100mm below the lid. This is to ensure the product temperature less than 36°F..

## DEFROSTING THE CABINET

In the course of time, a frost layer will be naturally formed within the cooler.

When this layer is 5-8mm thick, the cabinet should be defrosted the following way:

- remove the plug from the socket;
- open the lid and leave it open;
- loosen the frost layer using a plastic or wooden scraper.

The defrosting process can be speeded up by using bowls of hot water.

### **Never use sharp or pointed instruments**

After final defrosting, the cabinet should be cleaned as described in section: Maintenance. the cabinet should be thoroughly dried after cleaning.

# OPERATION



Do not throw items into the storage area. Failure to heed these recommendations could result in damage to the interior of the cabinet.

## Refrigerated cycle

**Refrigerators:** During the refrigeration cycle, the evaporator fans will run continuously even when one or more doors are open. The door switch will activate the lights when opened.

1. Every 6 hours, the unit will turn off and to allow the evaporator coil to defrost. The controller now displays the defrost symbol. When the coil temperature reaches 41°F or after 20 minutes of defrost, the unit will turn on again.
2. Anti-condensation heaters on door frames work in conjunction with the compressor.
3. The factory setting for the temperature range is 34°F to 38° F.

## On/Off Switch:

An on/off switch is located on the front of the panel. When the unit is on, the switch will glow green.

## SOLID-STATE THERMOSTAT DESCRIPTIONS

### 1. FRONT PANEL COMMANDS



**SET:** To display target set point; in programming mode it selects a parameter or confirms an operation.

(DEF) To start a manual defrost

(UP) To view the latest alarm occurrence; in programming mode it browses the parameter codes or increases the display value

(DOWN) To view the latest alarm occurrence; in programming mode it browses the parameter codes or decreases the display value

## KEY COMBINATION

+ To lock & unlock the keyboard

**SET** + To enter in programming mode

**SET** + To return to the room temperature display

### 1.1 Function of LEDs

LED	MODE	FUNCTION
	ON	Compressor enabled
	Flashing	-Programming Phase (flashing with ) - Anti-short cycle delay enabled
	ON	Defrost enabled
	Flashing	- Programming Phase (flashing with ) - Drip time in progress
	ON	An temperature alarm happened

## 2. MAIN FUNCTIONS

### 2.1 HOW TO SEE THE SETPOINT

1. Push and immediately release the **SET** key: the display will show the set point value.
2. Push and immediately release the **SET** key or wait for 5 seconds to display the sensor value again.



### 2.2 HOW TO CHANGE THE SETPOINT

1. Hold the **SET** key for more than 2 seconds to change the set point value.
2. The value of the set point will be displayed and the ❄️ LED starts blinking.
3. To change the set value push the ▲ or ▼ key within 10s.
4. To set a new point value, push the SET key again or wait 10s.

### 2.3 HOW TO START A MANUAL DEFFROST

Hold the ❄️ key for more than 2 seconds and the manual defrost will start



### 2.4 HOW TO LOCK THE KEYBOARD

1. Hold the ▲ and ▼ keys for more than 3s.
2. The “POF” message will be displayed and the keyboard will be locked. At this point, it will be possible only to see the set point or the MAX or Min temperature stored.
3. If a key is pressed more than 3s the “POF” message will be displayed.



### 2.5 HOW TO UNLOCK THE KEYBOARD

Hold the ▲ and ▼ keys together for more than 3s, till the “POF” message is displayed.

## 3. ALARM SIGNALS

### HOW TO SEE THE ALARM AND RESET THE RECORDED ALARM

1. Hold the ▲ or ▼ key to display the alarm signals.
2. When the signal is displayed, hold the **SET** key until the “rst” message is displayed, and push the **SET** key again. The “rst” message starts blinking and the normal temperature will be displayed.

Message	Cause	Outputs
“P1”	Room probe failure	Compressor output according to par. “Con” and “COF”
“P2”	Evaporator probe failure	Defrost end is timed
“HA”	Maximum temperature alarm	Outputs unchanged.
“LA”	Minimum temperature alarm	Outputs unchanged.
“dA”	Door open	Regulation restarts
“EA”	External alarm	Output unchanged.
“CA”	Serious external alarm (i1F=bAL)	All outputs OFF.
“CA”	Pressure switch alarm (i1F=PAL)	All outputs OFF

## MAINTENANCE

This cooler can be cleaned using warm water and a mild detergent. Rinse with clean water to finish off.

**Never use detergents that contain chlorine.**

The lid may be cleaned in the same way as the cooler.

If a condenser and associated fan are fitted at the back bottom of the cooler, they can gather dust and dirt. If cleaning is necessary, they should be vacuumed with a soft brush.

**Please note that the parts behind the protective grille can be hot and rotating.**

### Cleaning the Condenser Coil

- For efficient operation, keep the condenser surface free of dust, dirt, and lint.
- We recommend cleaning the condenser coil at least once per month.
- Clean the condenser with a commercial condenser coil cleaner and a soft brush, available from any commercial refrigeration equipment retailer, or vacuuming the condenser with a shop vac or use CO<sub>2</sub>

## SAFETY PRECAUTIONS

- This refrigerator must be properly installed and located in accordance with the Installation Instructions before it is used.
- Do not allow children to climb, stand or hang on the shelves in the refrigerator. They could damage the refrigerator and seriously injure themselves.
- Do not touch the cold surfaces in the freezer compartment when hands are damp or wet. Skin may stick to these extremely cold surfaces.
- Do not store or use gasoline or other flammable vapors and liquids in the vicinity of this or any other appliance
- Keep fingers out of the “pinch point” areas; clearances between the doors and between the doors and cabinet are necessarily small; be careful closing doors when children are in the area.

**NOTE: We strongly recommend that any servicing be performed by a qualified individual.**

- Unplug the refrigerator before cleaning and making repairs.
- Setting temperature controls to the ZERO (0) position does not remove power to the light circuit, perimeter heaters, or evaporator fans.

### Refrigerant Disposal

Your old refrigerator may have a cooling system that uses “Ozone Depleting” chemicals. If you are throwing away your old refrigerator, make sure the refrigerant is removed for proper disposal by a qualified service technician. If you intentionally release any refrigerants you can be subject to fines and imprisonment under provisions of the environmental regulations.

## ELECTRICAL WARNING

- Please ensure that the required voltage is being supplied at all times.
- The unit should be plugged into a grounded and properly-sized electrical outlet with appropriate over-current protection. **NEVER USE AN ADAPTER PLUG!**
- The unit should have its own dedicated outlet.
- Do not use extension cords.
- Do not unplug your unit by pulling on the power cord. Grip the plug firmly and pull straight out from the outlet.

## Service and Installation Manual

- Ensure the unit is not resting on or against the electrical cord.
- If the unit is not in use for a long period of time, best to unplug the unit from the outlet.
- To avoid shock and fire hazards, do not plug in or unplug the unit with wet hands.
- After unplugging the unit, wait at least 10 minutes before plugging it back in. Failure to do so could cause damage to the compressor.
- If the power cuts off, wait at least 5 minutes before turning the unit on to avoid damage to the compressor.

## TROUBLE SHOOTING

If you are having problems with your cooler, please check the following point before calling service personnel:

- Is the cooler connected to the power supply?
- Is the socket switch on?
- Is the fuse in the switch cabinet intact?
- Has the earth leak circuit breaker (if there is one) cut out?
- Has there been power cut?

If the cooler is in a place that is very hot or with bad ventilation, make sure to provide adequate ventilation. If the condenser mentioned in Section Maintenance is not clean, make sure to vacuum it.

If the above points have been checked and the cooler is still not working, please call service personnel. Inform them the nature of the problem, the type of cooler, serial number and item number (provided on the nameplate at the back of the cabinet).

Do not open the cabinet, as every opening hastens the thawing point. As a rule, the goods will not suffer damage at the first 12 hours. If more time passes, the goods must be moved to another cooler.

Fault	Probable Cause	Action
Compressor is Not Running	Fuse blown or circuit breaker tripped	Replace fuse or reset circuit breaker.
	Power cord unplugged	Plug in power cord
	Thermostat set too high	Set thermostat to lower temperature
Cabinet Temperature is too Warm	Thermostat is set too high	Set thermostat to lower temperature.
	Airflow is blocked	Re-arrange products to allow for proper air flow. Make sure there is at least four inches of clearance from the fan
	Low refrigerant levels	Contact a service technician to check refrigerant levels
	Door is slightly ajar	Make sure door is completely closed.
Interior Light is Not Working	Poor switch connection	Turn off light switch and turn it back on.
	Bulb is not connected	Make sure the bulb is correctly inserted in the socket.
	Bulb has burned out	Replace the bulb
Condensation is Collecting on the Cabinet and/or Floor	Gasket is not sealing properly	Clean, repair, or replace the gasket as necessary

## **DISPOSAL**

When a worn-out cooler is to be disposed off, this must be done in a correct manner, with respect to the environment. Please be aware of the rules covering the disposal of such terms; there may be special requirements or conditions to be observed.

Information about disposal may be obtained from:

- your supplier;
- the relevant authorities (the Local Authority, environmental agencies, etc.).

## **SPECIAL POINTS TO NOTE**

The information contained in these instruction for use, was correct at the term of printing. On account of our constant produce development, however, we reserve the right to make changes in the cooler described here. Naturally, we will attempt to keep instructions for use up to date.

If you are in doubt as to the correct use of the cooler, please contact your supplier, who will be able to advise you.

The producer is not responsible for accident or problems, occurred as a result of wrong connection of the cooler.



# WIRING DIAGRAM

MODEL: MXCR50B/ MXCR65B

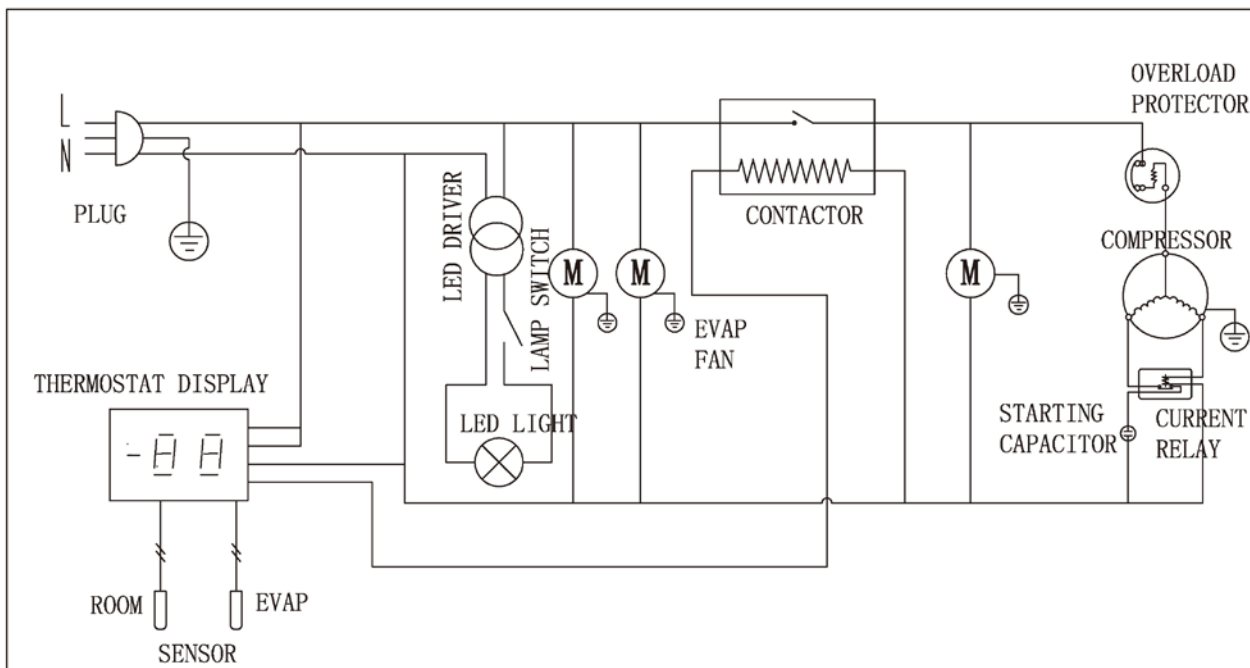

MODEL: MXCR96B

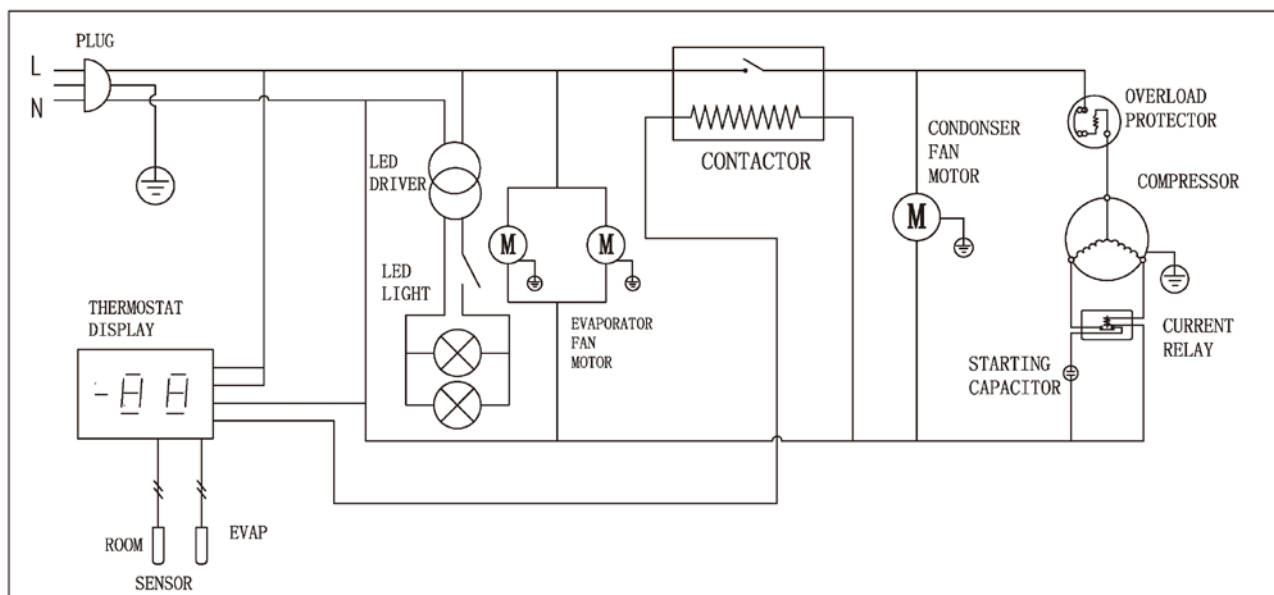

# WIRING DIAGRAM

MODEL: MXCR50B / MXCR65B

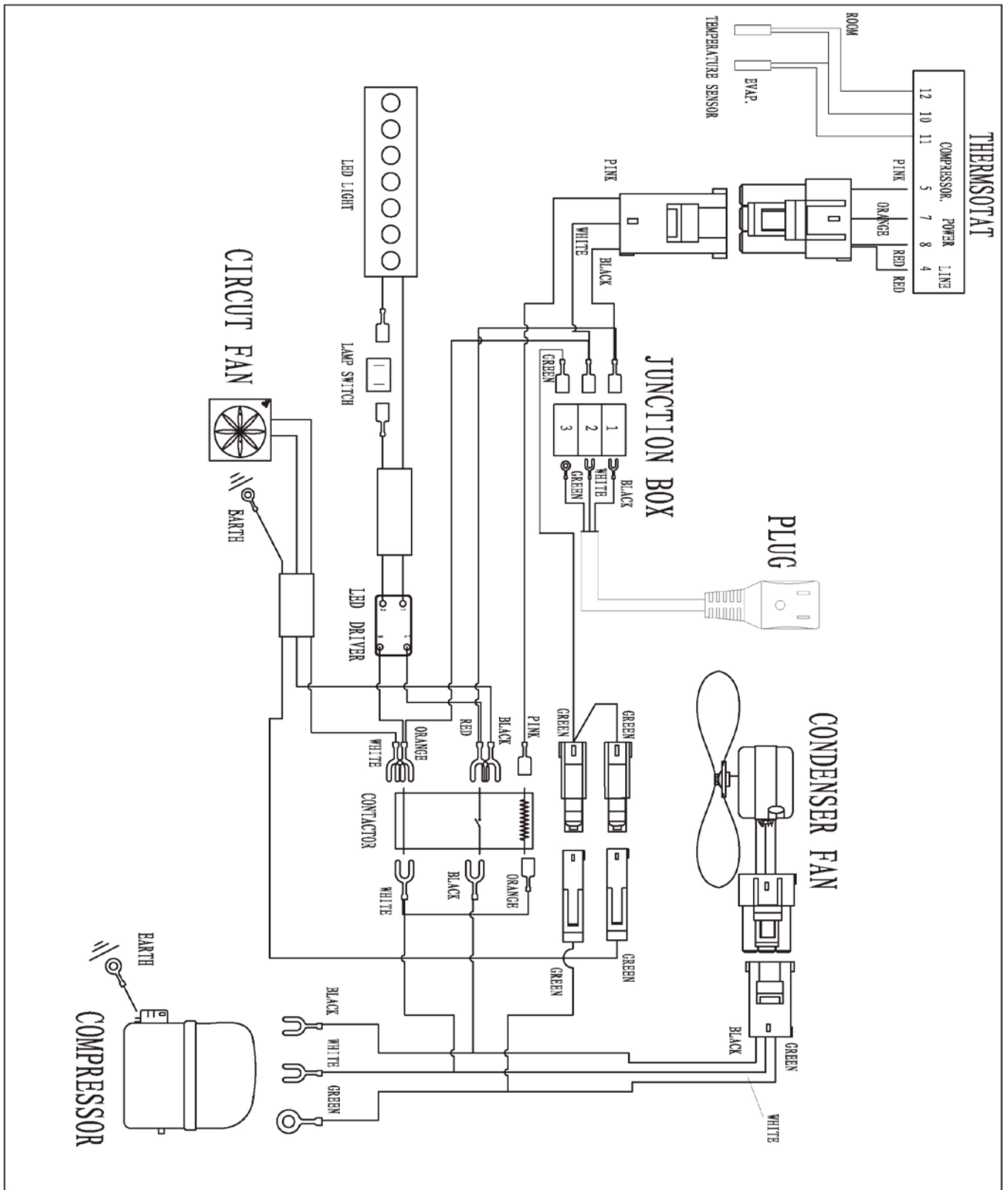

# WIRING DIAGRAM

MODEL: MXCR96B

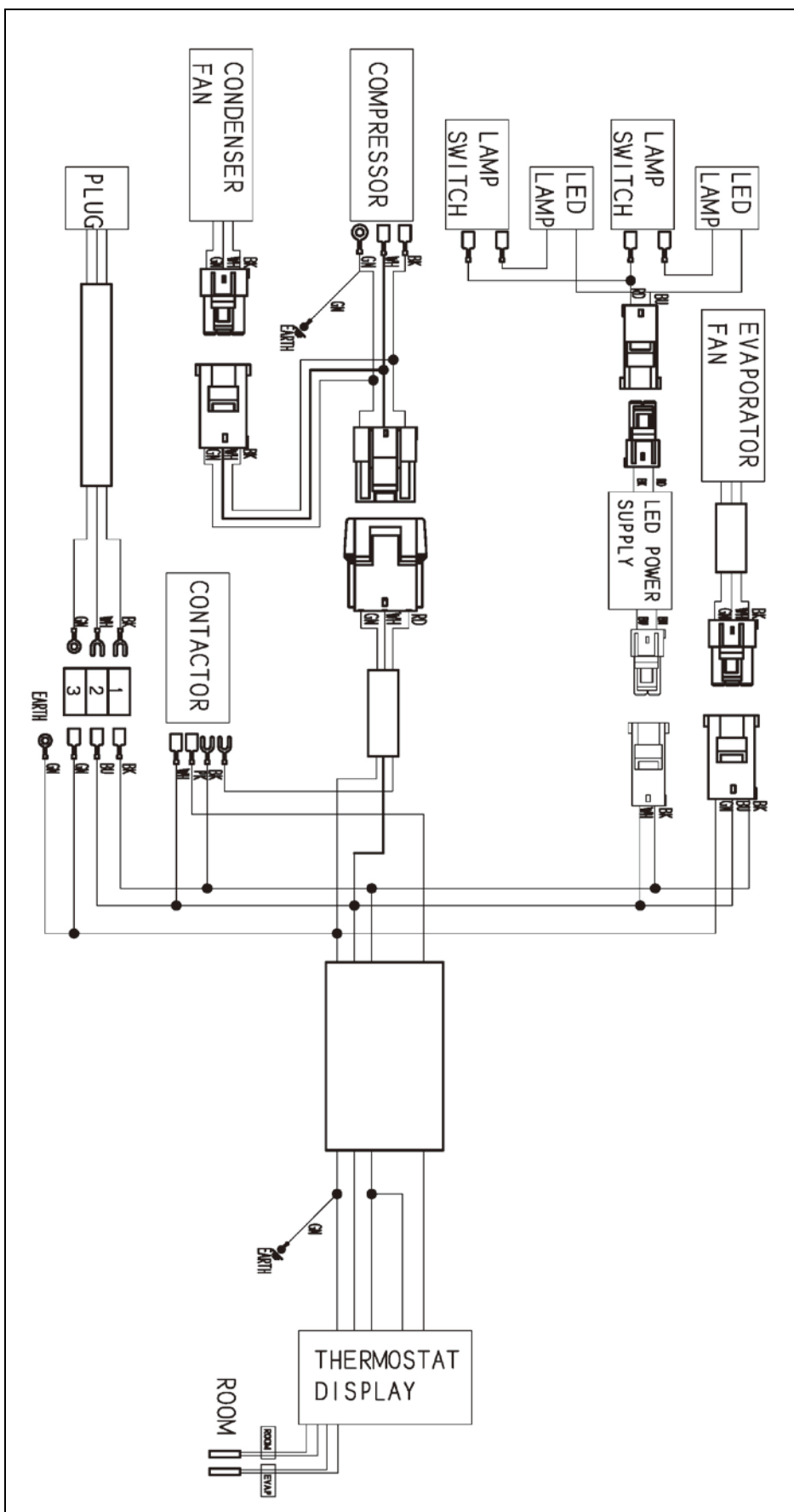



3355 Enterprise Ave., Suite 160 - Ft. Lauderdale, FL 33331  
T: (954) 202-1419 - F: (954) 202-7336  
[www.maxximumfoodservice.com](http://www.maxximumfoodservice.com)